

SIHI^{LPH-X} - Liquid Ring Vacuum Pump

One Stage



SIHI® Pumps

LPH 40106, LPH 40411, LPH 40516

Pressure Range: 150 to 1013 mbar
Suction Range: 50 to 270 m³/h

CONSTRUCTION

Sterling SIHI liquid ring vacuum pumps have a simple but robust construction with the following features and benefits:

- Near isothermal compression
- Oil free, with no internal lubrication
- Capable of handling almost all gases and vapours
- Able to handle quantities of liquid "carry over"
- Low maintenance and safe operation
- Low noise and almost vibration free
- Available in a wide range of materials
- Broad range of applications
- O-ring sealing as standard
- Cavitation protection as standard
- Drain hole as standard
- Built-in solids drain
- Rotating metallic parts are non contacting to minimise wear
- ATEX compliance

Sterling SIHI liquid ring vacuum pumps of the range LPH 40106, LPH 40411 and LPH 40516 are one stage pumps. They can be used as compressors up to a pressure of 1.2 bar without any modification (see the Technical Catalogue - Liquid Ring Compressors Part K).

APPLICATIONS

Evacuation and pumping of dry gases and saturated vapours. The pumps can also handle liquids. These units offer pressures in the range of 150...900 mbar(a) to atmospheric. Typical application areas include:

- Chemical and pharmaceutical industry for distillation, drying and degassing
- Electronic industry for impregnation and drying
- Plastics & Rubber industry for degassing
- Food and beverage industry for bottle filling.



NOTE

By continuously feeding the pump with a small amount of service liquid (usually water), the heat due to gas/vapour compression is conducted away. This also replenishes the liquid ring and ensures that it does not become saturated with process media. The condensed gas and fluid can be separated in a liquid separator (see Accessories Catalogue). Recharging the pump with service liquid at ambient temperature enables the unit to condense evacuated gases/vapours. It can therefore be used for solvent recovery. More information is provided in the accessory catalogues. The integrated solids drain permits the removal of any entrained solids whilst the pump is operating. The service liquid can, therefore, simply be re-circulated.

The rotation of the pump is clockwise when viewed from the drive end.

GENERAL TECHNICAL DATA

Pump Type	Units	LPH 40106	LPH 40411	LPH 40516
Speed	50 Hz 60 Hz	rpm rpm	1450 1740	
Maximum overpressure on compression	bar	0.6	0.8	0.4
Permissible pressure difference between suction and discharge side	max. min.	bar bar	1.2 0.2	1.2 0.2
Hydraulic test pressure (overpressure)	bar	3.0		
Moment of inertia of rotating parts of pump and water content	kg · m ²	0.0375	0.05	0.065
Noise level at 200 mbar suction pressure	dB (A)	65		
Minimum permissible pulley diameter for V belt drive	mm	160		
Maximum gas temperature	dry saturated	°C °C		
Service liquid:				
Maximum permissible temperature	°C	80		
Minimum permissible temperature	°C	10		
Maximum viscosity	mm ² /s	90		
Maximum density	kg/m ³	1200		
Liquid capacity up to middle of shaft	litre	3.5	4.5	5.5
Maximum flow resistance of the heat exchanger	bar	0.2		

In selecting a pump, avoid choosing one which is likely to be operating at a combination of its maximum permissible limits e.g. maximum viscosity and maximum permissible pressure difference.

Materials

Position number	Component	Materials	
		0K	4B
10.60	Casing	0.6025	1.4408
10.90	Central body		
13.70	Guide disc		1.4404
21.00	Shaft	1.4021	1.4408
23.50	Impeller	1.4308	1.4408
43.30, 43.31	Mechanical seal, Type SIHI FK (AG●)	Cr-Steel / Carbon / Butadiene rubber	Cr Ni Mo-Steel / Carbon / Viton
43.30, 43.31	Double mechanical seal	on request	

Cut-away diagram LPH 40106, LPH 40411, LPH 40516 with single and double mechanical seal

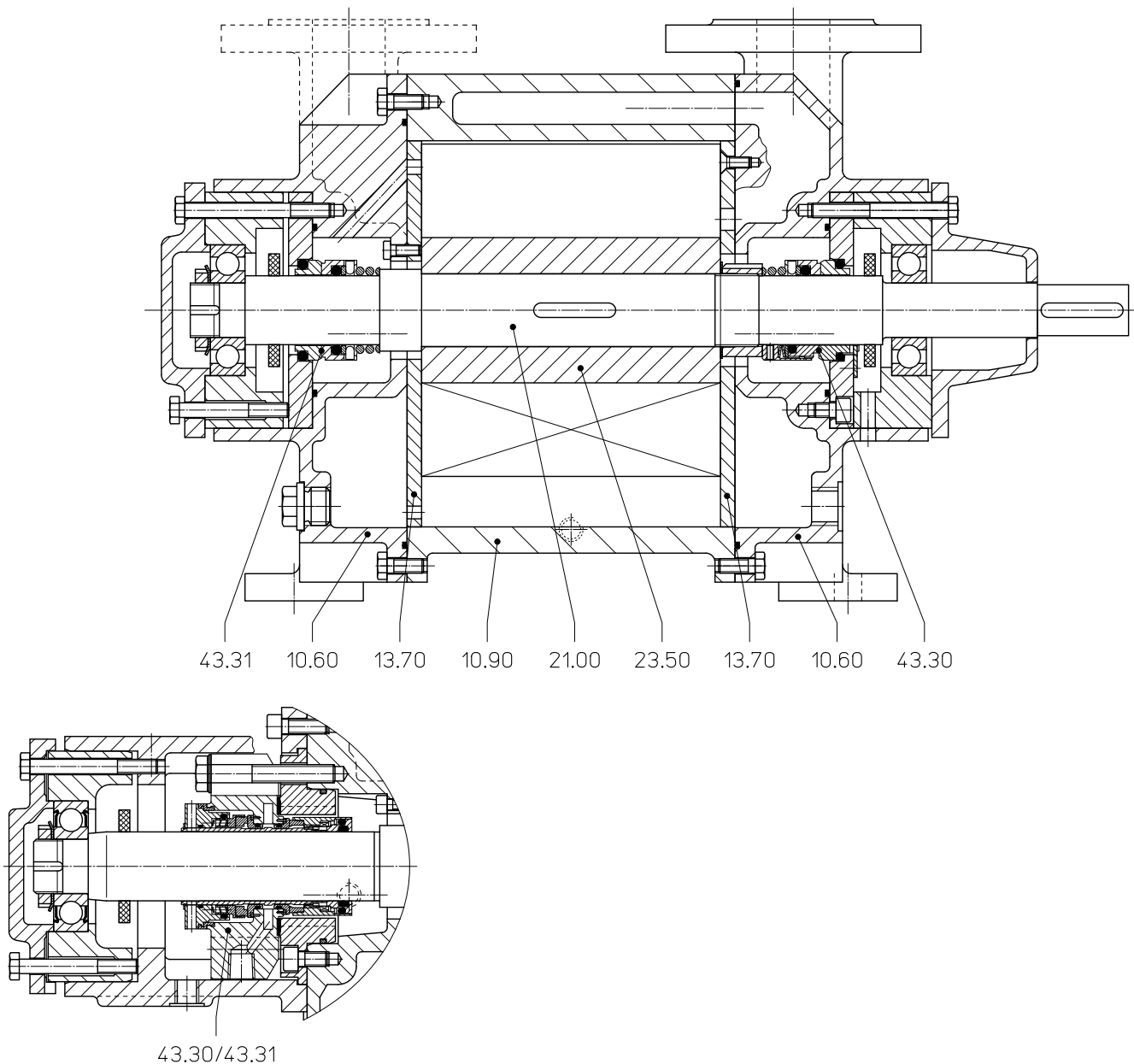

Performance Characteristics LPH 40106

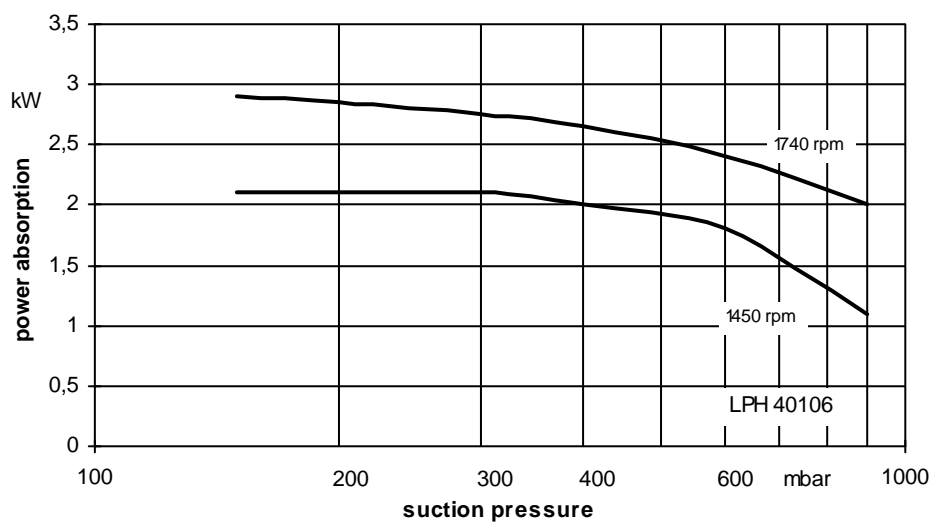
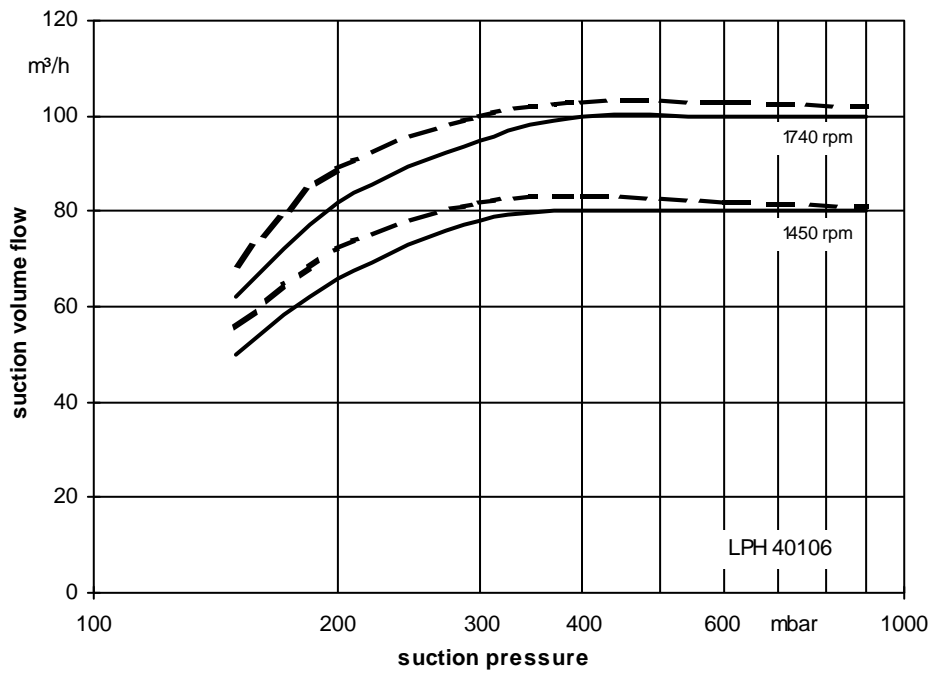

The operating data is valid under the following conditions:

- Process media:
 - dry air: 20°C —————
 - steam saturated air: 20°C - - - - -
- Service liquid:
 - water: 15°C

Pressure of gas to be evacuated: 1013 mbar (Atmospheric pressure)

The suction volume is related to the suction pressure.

Tolerance for the suction volume flow is 10% and for power 5%.

The maximum consumption of make up water occurs at the lowest suction pressure.

Performance Characteristics LPH 40411

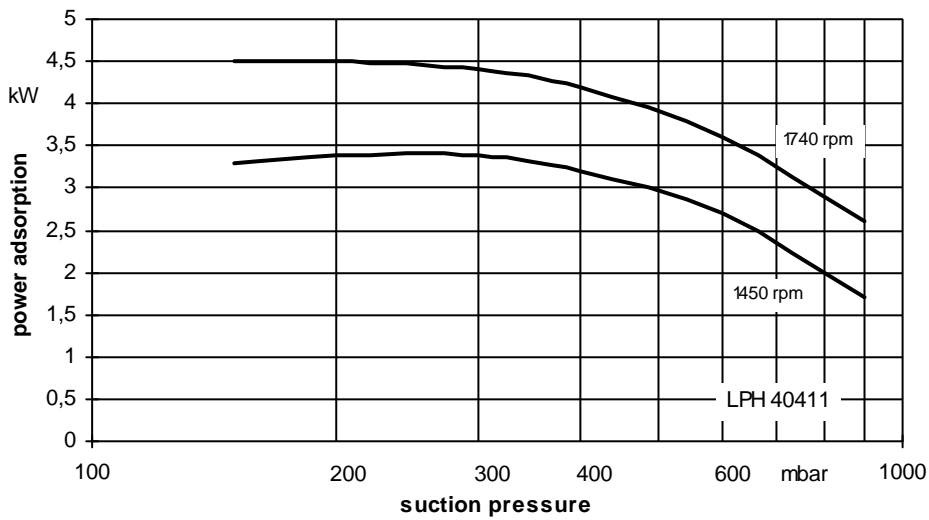
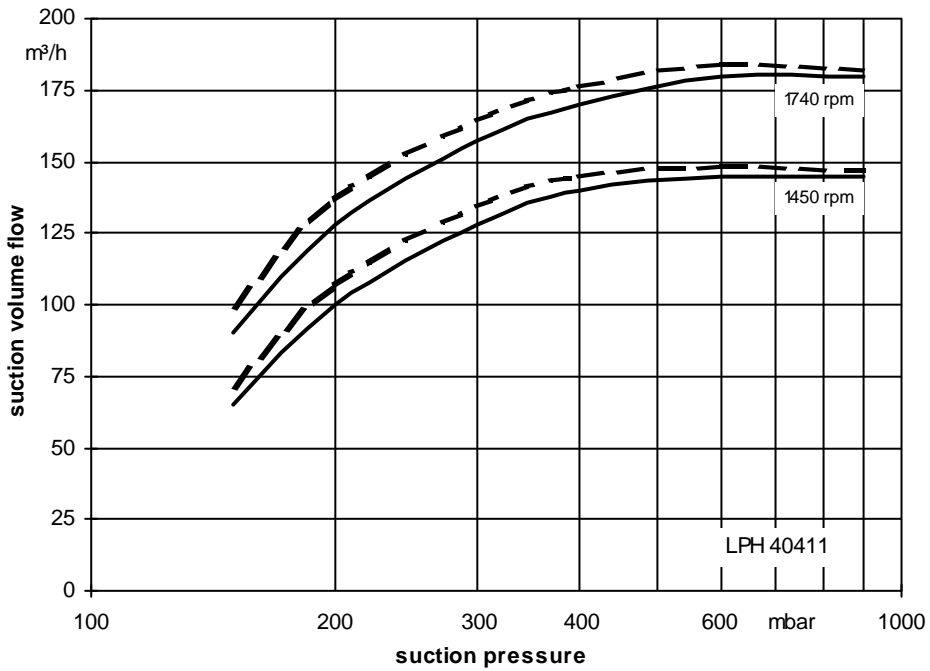

The operating data is valid under the following conditions:

- Process media:
 - dry air: 20°C —————
 - steam saturated air: 20°C - - - - -
- Service liquid:
 - water: 15°C

Pressure of gas to be evacuated: 1013 mbar (Atmospheric pressure)

The suction volume is related to the suction pressure.

Tolerance for the suction volume flow is 10% and for power 5%.

The maximum consumption of make up water occurs at the lowest suction pressure.

Performance Characteristics LPH 40516

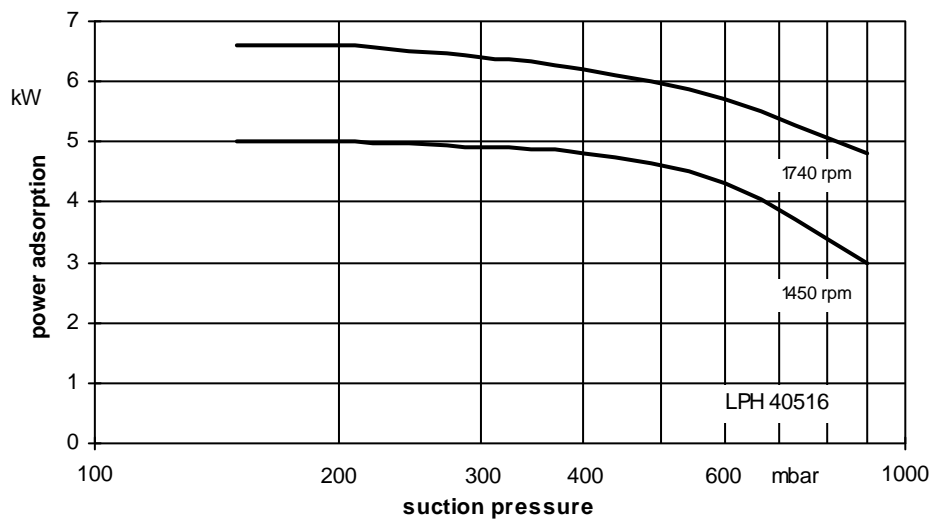
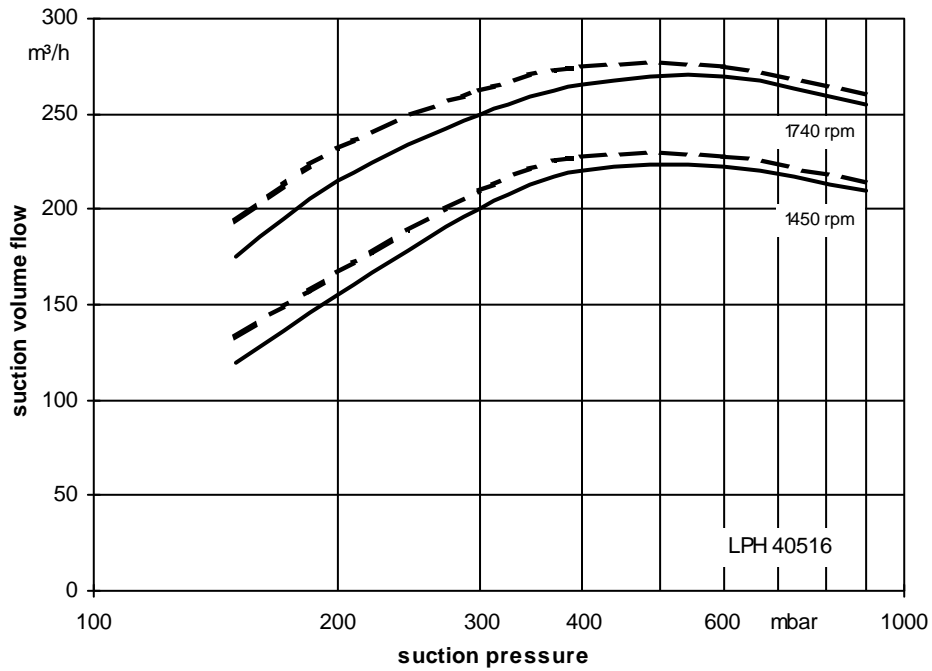

The operating data is valid under the following conditions:

- Process media:
 - dry air: 20°C
 - steam saturated air: 20°C

- Service liquid:
 - water: 15°C

Pressure of gas to be evacuated: 1013 mbar (Atmospheric pressure)

The suction volume is related to the suction pressure.

Tolerance for the suction volume flow is 10% and for power 5%.

The maximum consumption of make up water occurs at the lowest suction pressure.

Dimensions LPH 40106, LPH 40411, LPH 40516 with single mechanical seal

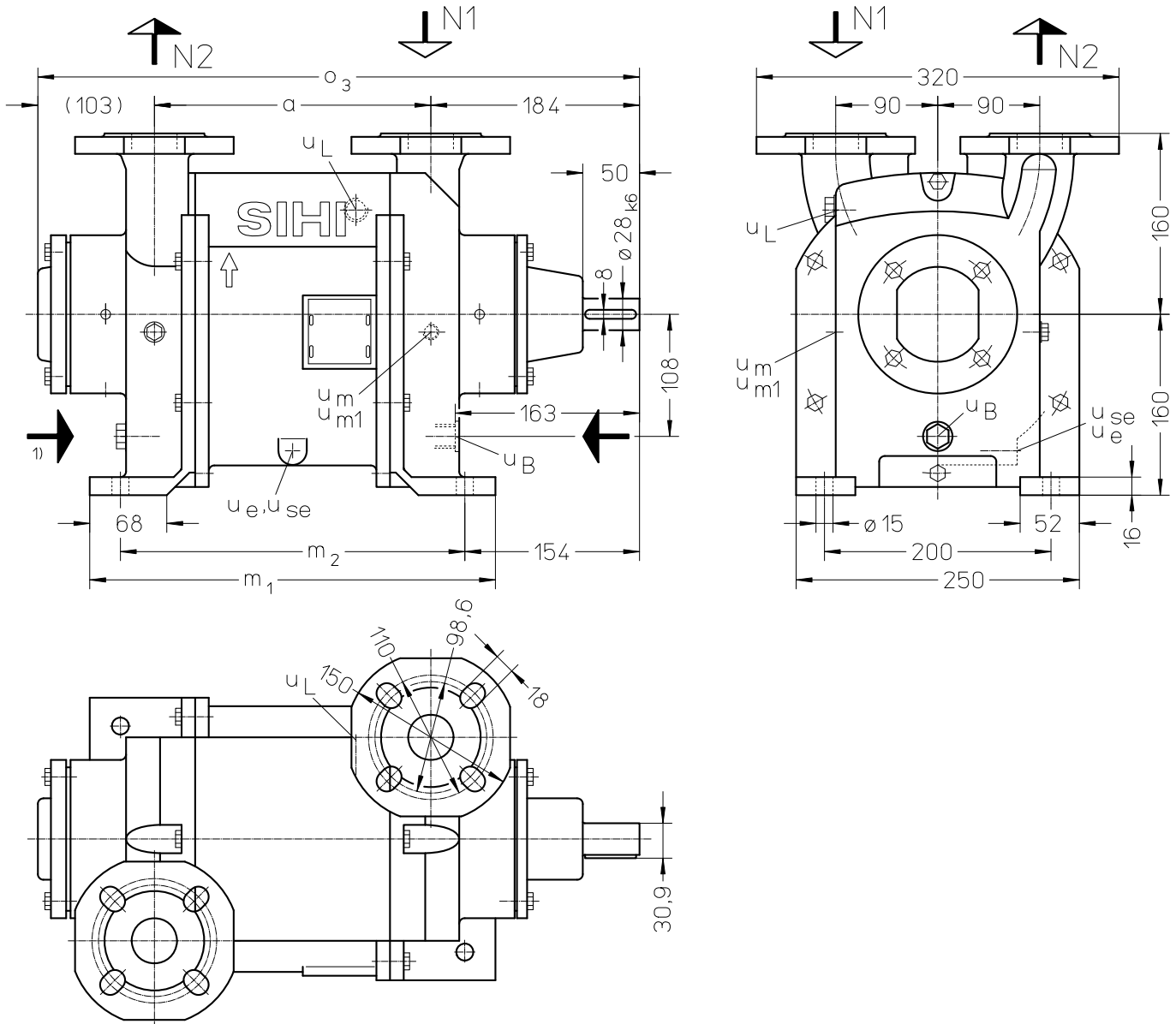

1) = Connection u_B on both sides is only necessary for LPH 40516

- N1 = Gas inlet DN 40 (according to DIN 2501 PN 10)
Gas inlet 1 ½" (according to ANSI 150 lbs)
- N2 = Gas outlet DN 40 (according to DIN 2501 PN 10)
Gas outlet 1 ½" (according to ANSI 150 lbs)
- u_B = Connection for service liquid G ½
- u_e = Connection for drain G ⅛
- u_{se} = Connection for dirt drain G ⅛
- u_l = Connection for air cock G ½
- u_m = Connection for pressure gauge G ¼
- u_{m1} = Connection for drainage valve or liquid level sensor G ¼

	a [mm]	m ₁ [mm]	m ₂ [mm]	o ₃ [mm]	approx. weight [kg]
LPH 40106	144	258	204	431	55
LPH 40411	194	308	254	481	60
LPH 40516	244	358	304	531	65

LPH 40106, LPH 40411, LPH 40516 with single mechanical seal and top-mounted liquid separator

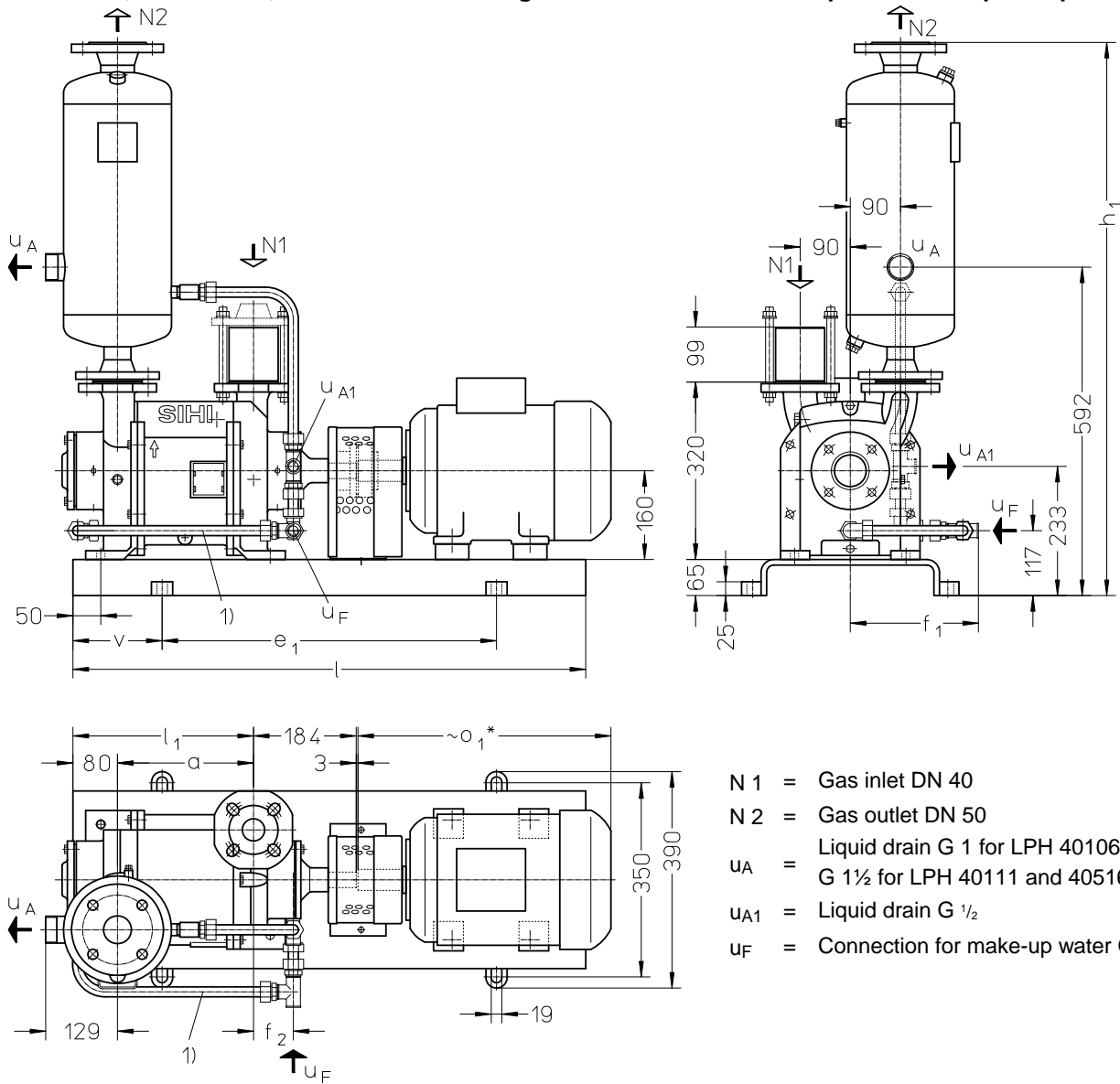

- N 1 = Gas inlet DN 40
- N 2 = Gas outlet DN 50
- U A = Liquid drain G 1 for LPH 40106,
G 1½ for LPH 40111 and 40516
- U A1 = Liquid drain G ½
- U F = Connection for make-up water G ½

1) = pipework to second side is only for LPH 40516

	electric motor 50 Hz			base-plate	a [mm]	f ₁ [mm]	f ₂ [mm]	e ₁ [mm]	h ₁ [mm]	l [mm]	l ₁ [mm]	v [mm]	o ₁ * [mm]	approx. weight [kg]
	size	IP 55	kW EEEx e II T3											
LPH 40106	100 L	2.2	-	S301	144	178	116	480	877	730	224	125	305	115
	100 L	3.0	-											120
	100 L	-	2.5											120
LPH 40411	112 M	4.0	-	S303	194	72	600	997	920	274	160	320	140	
	112 M	-	3.6										145	
	132 S	-	5.0										175	
LPH 40516	132 S	5.5	-	244	230					324		405	165	
	132 M	-	6.8										200	

* dimensions dependent upon motor supplier

flange connections according to DIN 2501 PN 10 [mm]		
DN	40	50
k	110	125
D	150	165
number x d ₂	4 x 18	4 x 18

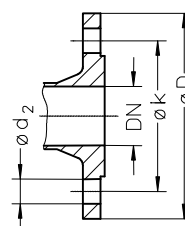

LPH 40106, LPH 40411 with single mechanical seal and side-mounted liquid separator

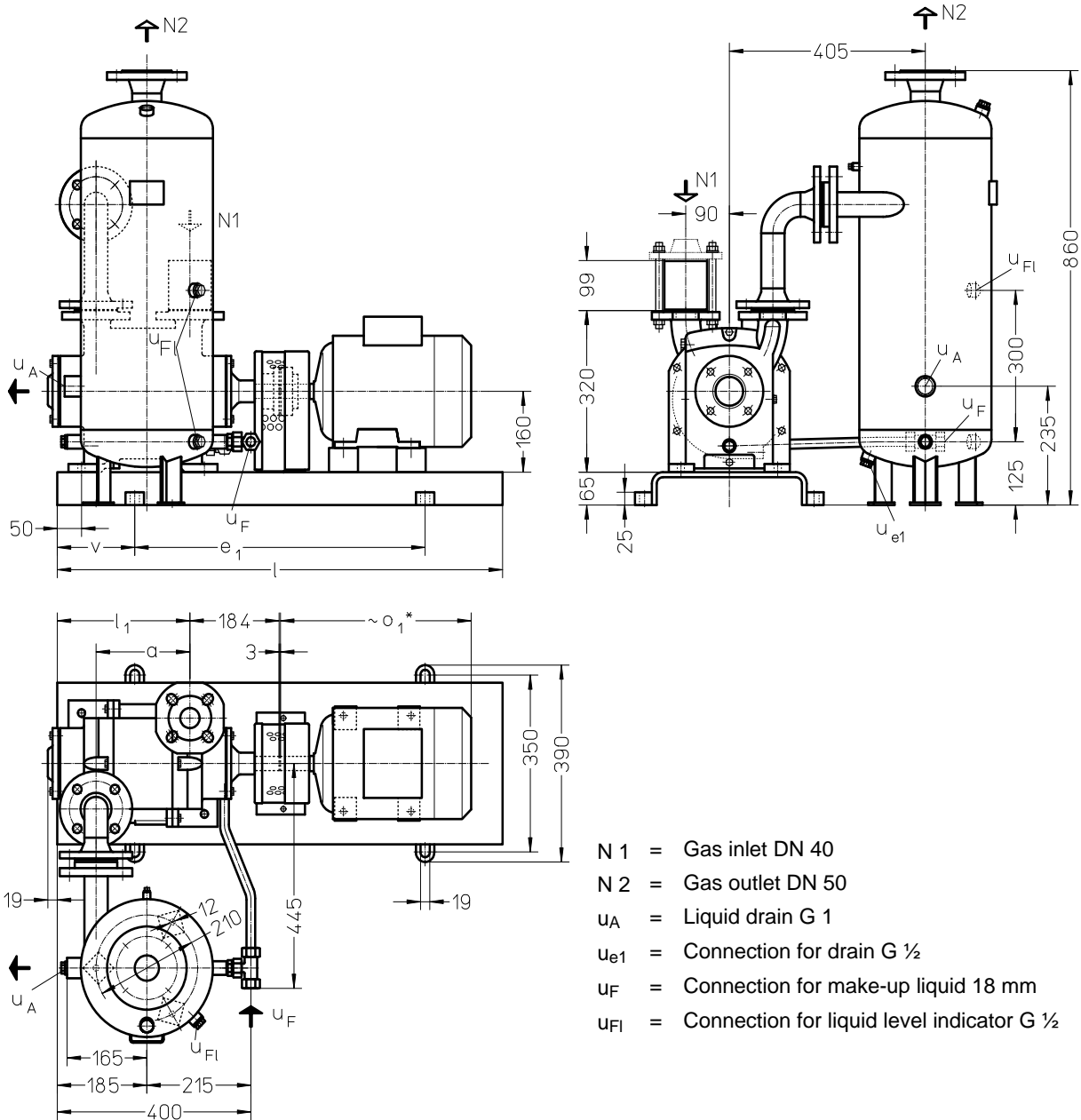

- N 1 = Gas inlet DN 40
- N 2 = Gas outlet DN 50
- u_A = Liquid drain G 1
- u_{e1} = Connection for drain G ½
- u_F = Connection for make-up liquid 18 mm
- u_{FI} = Connection for liquid level indicator G ½

	electric motor 50 Hz			base-plate	a [mm]	e ₁ [mm]	l [mm]	l ₁ [mm]	v [mm]	o ₁ * [mm]	approx. weight [kg]
	size	IP 55	kW EEx e II T3								
LPH 40106	100 L	2.2	-	S301	144	480	730	224	125	305	135
	100 L	3.0	-								140
	100 L	-	2.5								140
LPH 40411	112 M	4.0	-	S303	194	600	920	274	160	320	160
	112 M	-	3.6								165
	132 S	-	5.0								195

* dimensions dependent upon motor supplier

flange connections according to DIN 2501 PN 10 [mm]		
DN	40	50
k	110	125
D	150	165
number x d ₂	4 x 18	4 x 18

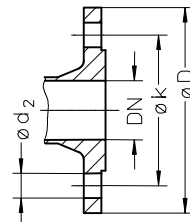

LPH 40516 with single mechanical seal and side-mounted liquid separator

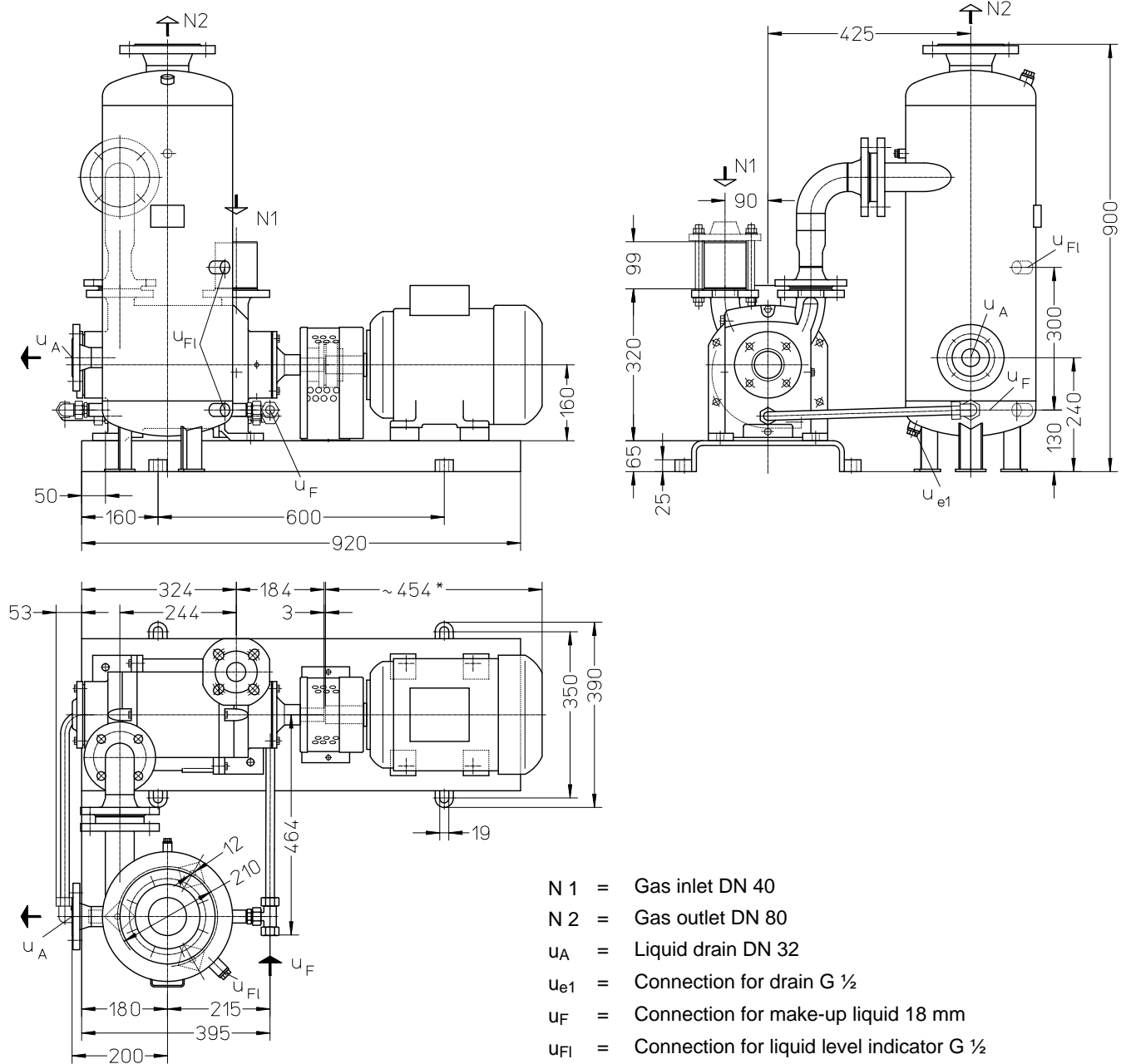

	electric motor 50 Hz			base-plate	approx. weight [kg]
	size	IP 55	kW EEx e II T3		
LPH 40516	132S	5.5	-	S 303	185
	132 M	-	6.8		220

* dimensions dependent upon motor supplier

flange connections according to DIN 2501 PN 10 [mm]			
DN	32	40	80
k	100	110	160
D	140	150	200
number x d ₂	4 x 18	4 x 18	8 x 18

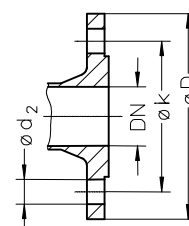

Make-up Liquid Consumption in [m³/h] dependent upon suction pressure, speed, drive type and temperature difference.

suction pressure in [mbar]		150				400				600				900							
pump type	speed [rpm]	KB				FB	KB				FB	KB				FB					
		temperature difference [°C]					temperature difference [°C]					temperature difference [°C]									
		20	10	5	2		20	10	5	2		20	10	5	2		20	10	5	2	
LPH 40106	1450	0.08	0.15	0.25	0.42	0.8	0.08	0.14	0.22	0.37	0.65	0.06	0.11	0.17	0.26	0.4	0.04	0.06	0.10	0.14	0.2
	1740	0.11	0.19	0.31	0.49		0.10	0.17	0.27	0.41		0.08	0.14	0.20	0.29		0.06	0.09	0.13	0.16	
LPH 40411	1450	0.12	0.21	0.33	0.51		0.11	0.19	0.30	0.44		0.5	0.09	0.16	0.24	0.35	0.05	0.08	0.12	0.16	
	1740	0.16	0.26	0.39	0.57		0.14	0.23	0.34	0.48			0.12	0.19	0.28	0.38	0.07	0.11	0.14	0.17	
LPH 40516	1450	0.19	0.35	0.58	0.98	1.8	0.18	0.32	0.52	0.83	1.4	0.16	0.27	0.42	0.65	1.0	0.08	0.11	0.14	0.17	
	1740	0.24	0.43	0.70	1.10		0.22	0.39	0.60	0.92		0.20	0.33	0.49	0.71		0.10	0.13	0.16	0.18	

FB = Total service liquid flow rate on once-through system

KB = Flow of makeup water when combined with partial recirculation liquid at a temperature of 20°C, 10°C, 5°C, 2°C warmer than make-up water.

Data regarding the pump size - order notes

Range + Size	Hydraulic + Bearings	Shaft Seal	Materials	Casing Sealing
	<ul style="list-style-type: none"> •A 1. hydraulic •B two greased roller bearings 	AGE Mechanical seal Type SIHI FK, O-rings butadiene rubber AG1 Mechanical seal Type SIHI FK, O-rings Viton	0K Main parts out of cast iron, impeller in low alloyed steel 4B Main parts out of stainless steel	1 O-ring-sealing
LPH 40106 40411 40516	AB	AGE, AG1	0K, 4B	1

Motor Selection

For our products we offer a lot of different motor types.

To identify the right motor please specify frequency, voltage and protection class.

Example of an Order:

LPHX 40106 AB AGE 0K 1 with 3.0 kW AC motor, 50 Hz, 400V Δ, IP55

Spare Parts Order Number

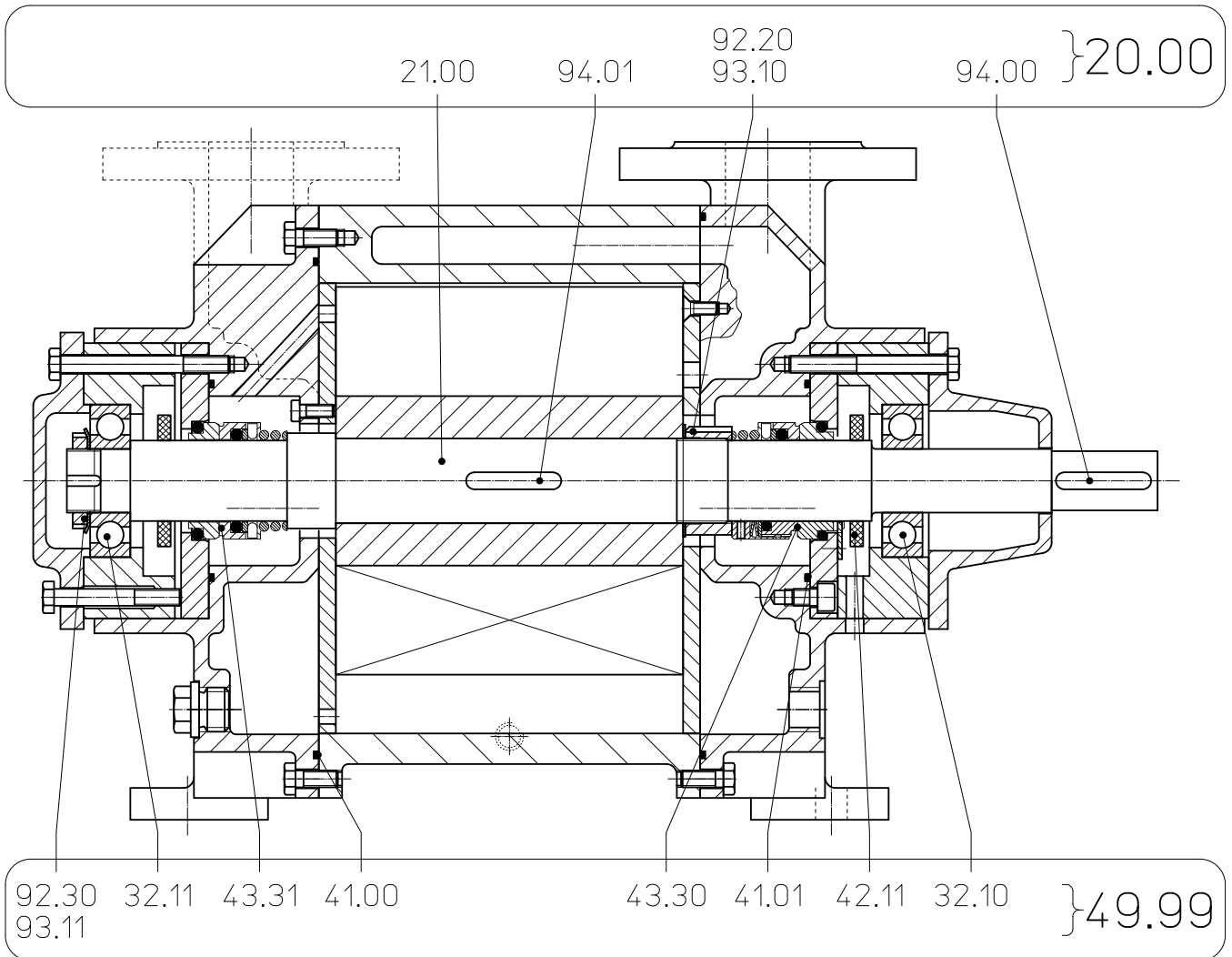

Material Design 0K				
Group	Spare parts kit	LPH 40106	LPH 40411	LPH 40516
20.00	Shaft	65 006 715	65 006 714	65 006 713
49.99	Basic Repair AGE	65 008 221		

Material Design 4B				
Group	Spare parts kit	LPH 40106	LPH 40411	LPH 40516
20.00	Shaft	65 006 754	65 006 755	65 006 756
49.99	Basic Repair AG1	65 008 223		

Accessories

Recommended Accessory	Material Execution		LPH 40106	LPH 40411	LPH 40516
Top Mounted Liquid Separator		Type / Weight	XBa 1040 / 10 kg		XBa 1340 / 14 kg
Top mounted separator	Steel, galvanised 1.4571	SIHI-Part No.	43 133 417 43 132 191	- 43 132 193	
Service liquid pipework, standard execution	Steel, galvanised 1.4571	SIHI-Part No.	20 054 515 20 054 517	20 058 985 20 058 993	20 058 986 20 058 995
Service liquid pipework, thermostatic control 24V	Steel, galvanised + Brass 1.4571 + Brass	SIHI-Part No.	20 059 008 20 048 978		on request
Side Mounted Liquid Separator		Type / Weight	XBp 0413 / 28 kg		XBp 0414 / 31 kg
Side mounted separator	Steel, galvanised 1.4571	SIHI-Part No.	35 000 502 43 132 218		35 000 504 35 000 505
Service liquid pipework, standard execution	Steel, galvanised 1.4571	SIHI-Part No.	20 058 982 20 058 990	20 058 983 20 058 991	20 058 984 20 058 992
Service liquid pipework, thermostatic control 24V	Steel, galvanised + Brass 1.4571 + Brass	SIHI-Part No.	20 059 099 20 059 100		20 094 388 on request
Pressure pipework (bend)	1.0254 1.4571	SIHI-Part No.	35 003 165 35 003 166		35 023 751 35 023 750
Liquid level indicator	Brass / Plexiglas 1.4571 / Plexiglas	SIHI-Part No.	43 014 911 43 040 384		
Sterling SIHI - Non Return Ball Valve					
Intermediate flange execution XCk 40	0.6025 + Butadiene Rubber 0.6025 + Teflon 1.4408 + Teflon	SIHI-Part No. Weight	20 072 746 / 2.8 kg 20 072 745 / 2.8 kg 20 029 494 / 5.2 kg		
Flange execution with glass cylinder XCk 406	0.6025 + Butadiene Rubber 0.6025 + Teflon 1.4408 + Teflon	SIHI-Part No. Weight	20 072 835 / 7.0 kg 20 072 836 / 7.0 kg 20 072 834 / 7.0 kg		
Adapter Flange	Steel 1.4571	SIHI-Part No.	not necessary	1 x 20 059 826 1 x 20 060 458	1 x 20 059 827 1 x 20 060 489
Drain Valve XCg 015	Steel 1.4571	SIHI-Part No.	43 014 545 43 014 546		
Double nipple 1/2"-1/4"	Steel, galvanised 1.4571	SIHI-Part No.	43 049 216 43 013 084		
Air Inlet Valve	Brass 1.4408	SIHI-Part No.	43 014 257 + 43 060 102 43 014 271		
Motor					
Motor standard execution IP 55		Size Power Weight	100 L 2.2 kW 18 kg	100 L 3.0 kW 20 kg	112 M 4.0 kW 28 kg
Coupling for motor IP 55 Pump side Motor side		Type / Weight SIHI-Part No.	B 80 / 1.5 kg 43 021 414 43 021 417		B 95 / 2.6 kg 43 021 426 43 021 433
Coupling guard	Steel	SIHI-Part No.	43 042 248		
Motor in EEx e II T3 execution		Size Power Weight	100 L 2.5 kW 22 kg	112 M 3.6 kW 30 kg	132 S 5.0 kW 65 kg
Coupling for Motor EEx e II T3 Pump side Motor side		Type / Weight SIHI-Part No.	BDS 88 / 2.0 kg 43 111 058 43 111 029		BDS 103 / 3.1 kg 43 111 051 43 111 040
Coupling guard	Brass	SIHI-Part No.	43 042 249		
Baseplate	Steel	Type / Weight SIHI-Part No.	S 301 / 27 kg 43 040 634	S 303 / 34 kg 43 040 635	

Designs subject to change without prior notice.

Sterling SIHI GmbH

Lindenstraße 170, D-25524 Itzehoe, Germany, Tel. +49 (0) 48 21 / 7 71 - 01, Fax +49 (0) 48 21 / 7 71-274